

X20(c)PS3300

1 General information

The supply module is equipped with a feed for the X2X Link as well as the internal I/O supply.

- Feed for X2X Link and internal I/O supply
- Electrical isolation of feed and X2X Link supply
- Redundancy of X2X Link supply possible by operating multiple supply modules simultaneously

2 Coated modules

Coated modules are X20 modules with a protective coating for the electronics component. This coating protects X20c modules from condensation and corrosive gases.

The modules' electronics are fully compatible with the corresponding X20 modules.

For simplification purposes, only images and module IDs of uncoated modules are used in this data sheet.

The coating has been certified according to the following standards:

- Condensation: BMW GS 95011-4, 2x 1 cycle
- Corrosive gas: EN 60068-2-60, method 4, exposure 21 days



3 Order data

Model number	Short description	Figure
	Power supplies	
X20PS3300	X20 power supply module, for X2X Link and internal I/O power supply	
X20cPS3300	X20 power supply module, coated, for X2X Link and internal I/O power supply	
	Required accessories	
	Bus modules	
X20BM01	X20 power supply bus module, 24 VDC keyed, internal I/O supply interrupted to the left	
X20BM05	X20 power supply bus module, with node number switch, 24 VDC keyed, internal I/O supply interrupted to the left	
X20cBM01	X20 power supply bus module, coated, 24 VDC keyed, internal I/O supply interrupted to the left	
	Terminal blocks	
X20TB12	X20 terminal block, 12-pin, 24 VDC keyed	

Table 1: X20PS3300, X20cPS3300 - Order data

4 Technical data

Model number	X20PS3300	X20cPS3300
Short description		
Power supply module	24 VDC supply module for I/O and bus	
General information		
B&R ID code	0x1BC0	0xDF13
Status indicators	Overload, operating state, module status	
Diagnostics		
Module run/error	Yes, using status LED and software	
Overload	Yes, using status LED and software	
Power consumption of X2X Link power supply ¹⁾	1.42 W	
Power consumption ¹⁾		
Internal I/O	0.6 W	
Additional power dissipation caused by actuators (resistive) [W]	-	
Certifications		
CE	Yes	
KC	Yes	-
UL	cULus E115267 Industrial control equipment	
HazLoc	cCSAus 244665 Process control equipment for hazardous locations Class I, Division 2, Groups ABCD, T5	
ATEX	Zone 2, II 3G Ex nA nC IIA T5 Gc IP20, Ta (see X20 user's manual) FTZÜ 09 ATEX 0083X	
DNV GL	Temperature: B (0 - 55°C) Humidity: B (up to 100%) Vibration: B (4 g) EMC: B (Bridge and open deck)	
LR	ENV1	
GOST-R	Yes	
X2X Link power supply input		
Input voltage	24 VDC -15% / +20%	
Input current	Max. 0.7 A	
Fuse	Integrated, cannot be replaced	
Reverse polarity protection	Yes	
X2X Link power supply output		
Nominal output power	7 W	
Parallel connection	Yes ²⁾	
Redundant operation	Yes	
Overload characteristics	Short circuit, temporary overload	
Input I/O power supply		
Input voltage	24 VDC -15% / +20%	
Fuse	Required line fuse: Max. 10 A, slow-blow	
Reverse polarity protection	No	
Output I/O power supply		
Nominal output voltage	24 VDC	
Behavior on short circuit	Required line fuse	
Permissible contact load	10 A	
Electrical characteristics		
Electrical isolation	X2X Link supply isolated from X2X Link power supply I/O supply not isolated from I/O power supply	
Operating conditions		
Mounting orientation		
Horizontal	Yes	
Vertical	Yes	
Installation elevation above sea level		
0 to 2000 m	No limitations	
>2000 m	Reduction of ambient temperature by 0.5°C per 100 m	
Degree of protection per EN 60529	IP20	
Environmental conditions		
Temperature		
Operation		
Horizontal mounting orientation	-25 to 60°C	
Vertical mounting orientation	-25 to 50°C	
Derating	See section "Derating"	
Storage	-40 to 85°C	
Transport	-40 to 85°C	

Table 2: X20PS3300, X20cPS3300 - Technical data

Model number	X20PS3300	X20cPS3300
Relative humidity		
Operation	5 to 95%, non-condensing	Up to 100%, condensing
Storage	5 to 95%, non-condensing	
Transport	5 to 95%, non-condensing	
Mechanical properties		
Note	Order 1x X20TB12 terminal block separately Order 1x X20BM01 supply bus module separately	Order 1x X20TB12 terminal block separately Order 1x X20cBM01 supply bus module separately
Spacing	12.5 ^{+0.2} mm	

Table 2: X20PS3300, X20cPS3300 - Technical data

- 1) The specified values are maximum values. For examples of the exact calculation, see section "Mechanical and electrical configuration" of the X20 system user's manual.
- 2) In parallel operation, only 75% of the rated power can be assumed. It is important to make sure that all power supplies operated in parallel are switched on and off at the same time.

5 LED status indicators

For a description of the various operating modes, see section "Additional information - Diagnostic LEDs" of the X20 system user's manual.

Figure	LED	Color	Status	Description
	r	Green	Off	No power to module
			Single flash	RESET mode
			Blinking	PREOPERATIONAL mode
			On	RUN mode
	e	Red	Off	No power to module or everything OK
			Double flash	LED indicates one of the following states: <ul style="list-style-type: none"> • The X2X Link supply for the power supply is overloaded • I/O supply too low • Input voltage for X2X Link supply too low
	e + r	Red on / Green single flash	Invalid firmware	
	l	Red	Off	The X2X Link supply is within the valid limits
			On	The X2X Link supply for the power supply is overloaded

6 Pinout

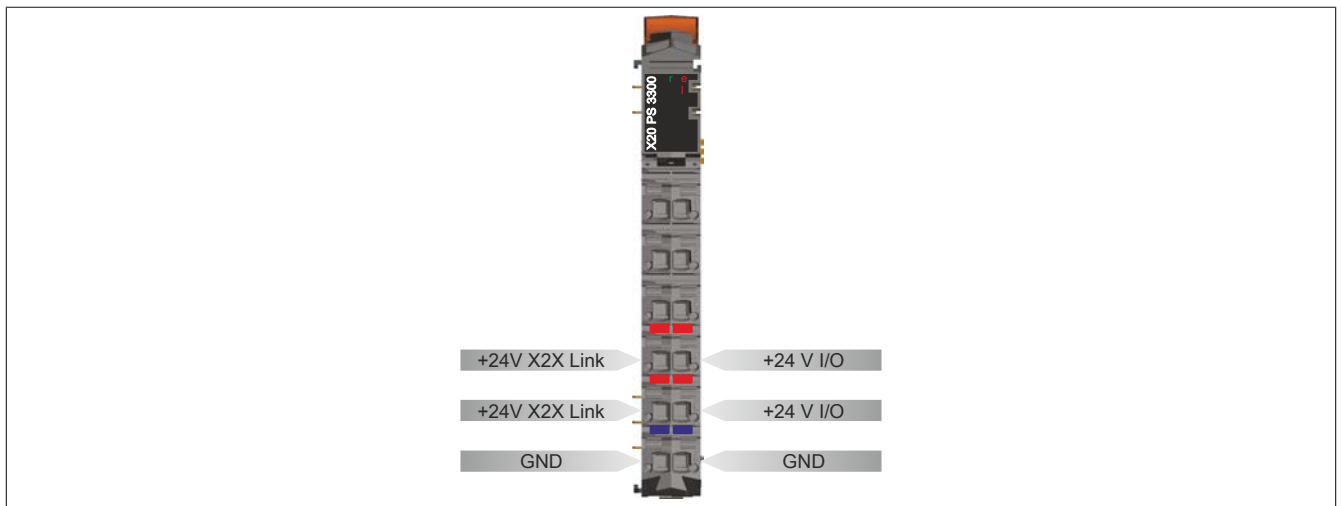

7 Connection examples

With 2 separate supplies

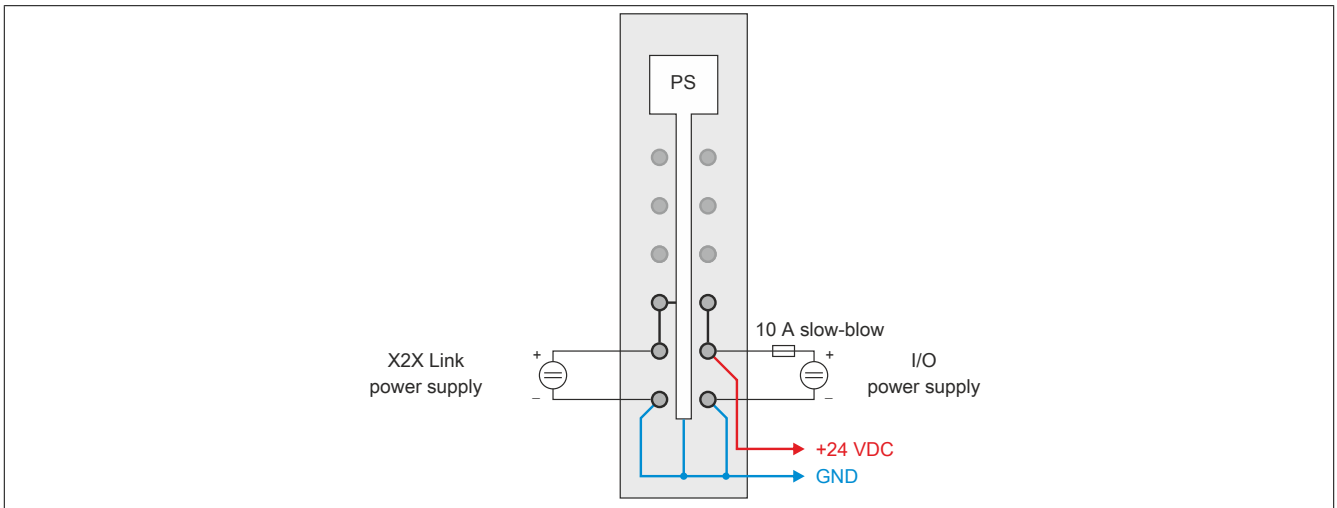

With a supply and jumper

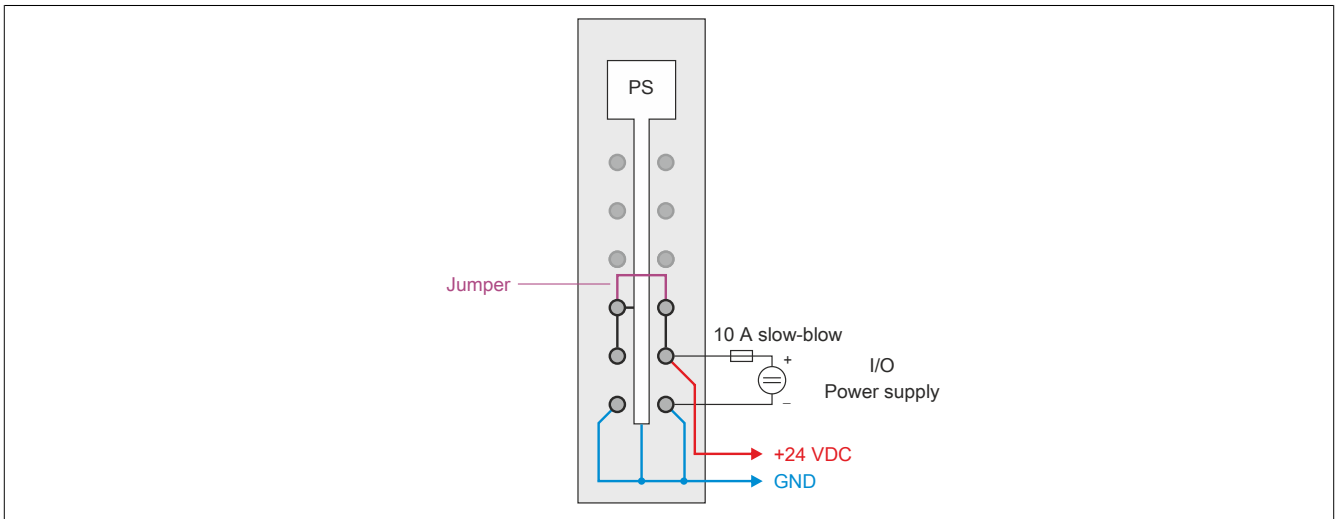

8 Derating

The nominal output power for the power supply is 7 W. Derating may need to be taken into account depending on the mounting orientation.

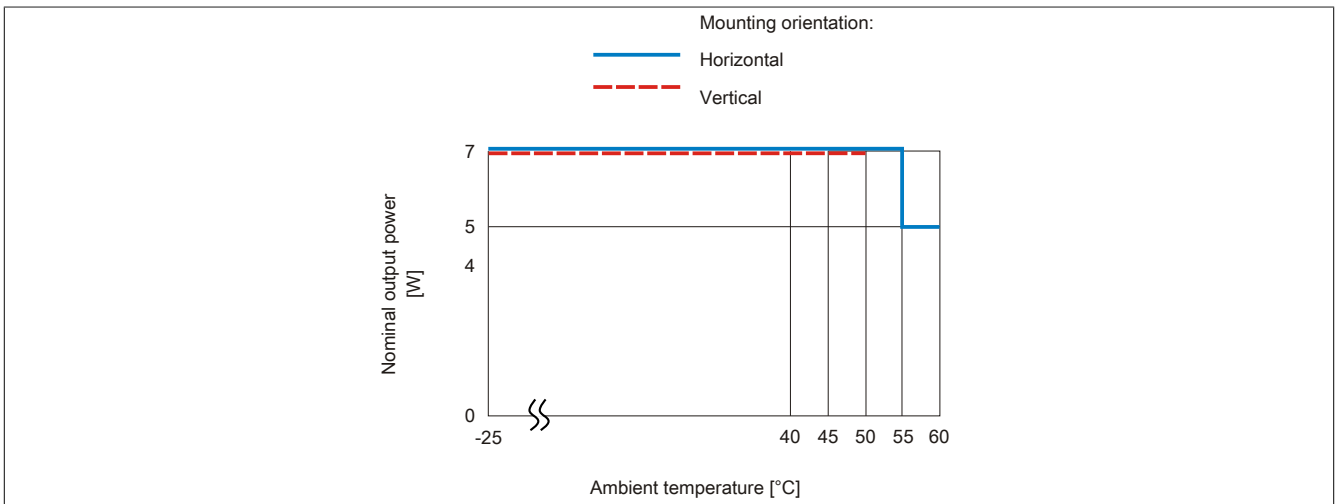

9 Register description

9.1 General data points

In addition to the registers listed in the register description, the module also has other more general data points. These registers are not specific to the module but contain general information such as serial number and hardware version.

General data points are described in section "Additional information - General data points" of the X20 system user's manual.

9.2 Function model 0 - Standard

Register	Fixed offset	Name	Data type	Read		Write	
				Cyclic	Non-cyclic	Cyclic	Non-cyclic
0	1	Module status	USINT	•			
		StatusInput01	Bit 0				
		StatusInput02	Bit 2				
2	2	SupplyCurrent	USINT	•			
4	3	SupplyVoltage	USINT	•			

Fixed modules require their data points to be in a specific order in the X2X frame. Cyclic access occurs according to a predefined offset, not based on the register address.

Acyclic access continues to be based on the register numbers.

9.3 Function model 254 - Bus controller

Register	Offset ¹⁾	Name	Data type	Read		Write	
				Cyclic	Non-cyclic	Cyclic	Non-cyclic
0	0	Module status	UINT	•			
		StatusInput01	Bit 0				
		StatusInput02	Bit 2				
2	2	SupplyCurrent	UINT	•			
4	4	SupplyVoltage	UINT	•			

1) The offset specifies the position of the register within the CAN object.

9.3.1 Using the module on the bus controller

Function model 254 "Bus controller" is used by default only by non-configurable bus controllers. All other bus controllers can use other registers and functions depending on the fieldbus used.

For detailed information, see section "Additional information - Using I/O modules on the bus controller" of the X20 user's manual (version 3.50 or later).

9.3.2 CAN I/O bus controller

The module occupies 1 analog logical slot on CAN I/O.

9.4 Module status

Name:

Module status

The following voltage and current states of the module are monitored in this register:

Bus supply current:	Bus supply current >2.3 A is displayed as a warning.
Bus supply voltage:	Bus supply voltage <4.7 V is displayed as a warning.
24 VDC I/O supply voltage:	I/O supply voltage <20.4 V is displayed as a warning.

Function model	Data type	Value
0 - Standard	USINT	See bit structure.
254 - Bus controller	UINT	See bit structure.

Bit structure:

Bit	Name	Value	Information
0	StatusInput01	0	No error
		1	Warning if overcurrent (>2.3 A) or undervoltage (<4.7 V)
1	Reserved	0	
2	StatusInput02	0	I/O power supply above the warning limit of 20.4 V
		1	I/O power supply below the warning limit of 20.4 V
3 - x	Reserved	0	

9.5 Bus supply current

Name:

SupplyCurrent

This register displays the bus supply current measured at a resolution of 0.1 A.

Function model	Data type
0 - Standard	USINT
254 - Bus controller	UINT

9.6 Bus supply voltage

Name:

SupplyVoltage

This register displays the bus supply voltage measured at a resolution of 0.1 V.

Function model	Data type
0 - Standard	USINT
254 - Bus controller	UINT

9.7 Minimum cycle time

The minimum cycle time defines how far the bus cycle can be reduced without communication errors occurring. It is important to note that very fast cycles reduce the idle time available for handling monitoring, diagnostics and acyclic commands.

Minimum cycle time
100 μ s

9.8 Minimum I/O update time

The minimum I/O update time defines how far the bus cycle can be reduced while still allowing an I/O update to take place in each cycle.

Minimum I/O update time
2 ms