

Features

- 1-channel signal conditioner
- 24 V DC supply (Power Rail)
- Input for 2- or 3-wire sensors, NAMUR sensors or dry contacts
- Input frequency 1 mHz ... 12 kHz
- Current output 0/4 mA ... 20 mA
- Relay contact and transistor output
- Start-up override
- Line fault detection (LFD)
- Up to SIL 2 acc. to IEC 61508/IEC 61511

Function

This signal conditioner provides the isolation for non-intrinsically safe applications.

The device is a universal frequency converter that changes a digital input signal into a proportional free adjustable 0/4 mA ... 20 mA analog output signal and functions as a switch amplifier and a trip alarm.

The functions of the switch outputs (2 relay outputs and 1 potential free transistor output) are easily adjustable [trip value display (min/max alarm), serially switched output, pulse divider output, error signal output].

The device is easily configured by the use of keypad or with the PACTware configuration software.

A fault is signaled by LEDs acc. to NAMUR NE44 and a separate collective error message output.

For additional information, refer to the manual and www.pepperl-fuchs.com.

Assembly

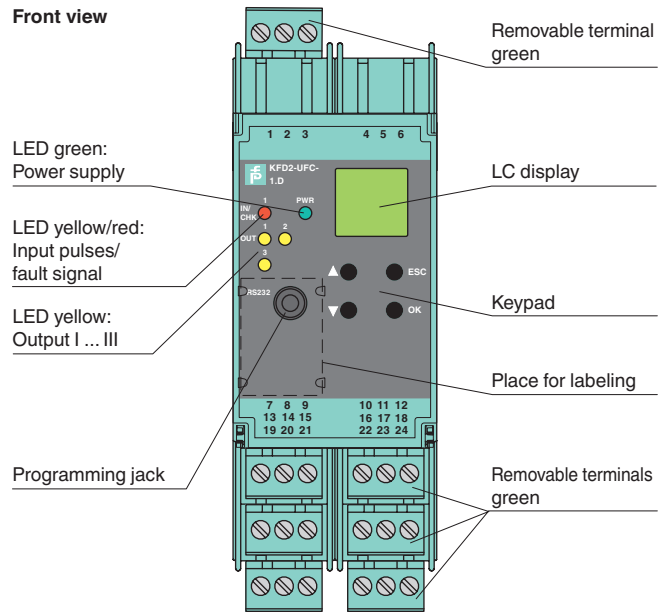

SIL 2

Connection

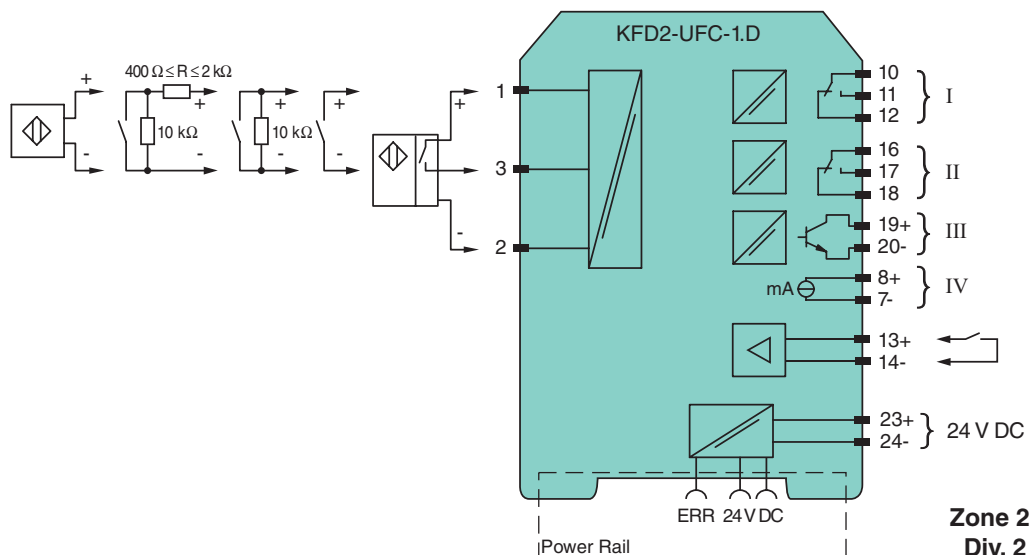

Release date 2018-05-08 08:06 Date of issue 2018-05-08 23:19:3_eng.xml

Refer to "General Notes Relating to Pepperl+Fuchs Product Information".

Pepperl+Fuchs Group
www.pepperl-fuchs.com

USA: +1 330 486 0002
pa-info@us.pepperl-fuchs.com

Germany: +49 621 776 2222
pa-info@de.pepperl-fuchs.com

Singapore: +65 6779 9091
pa-info@sg.pepperl-fuchs.com

General specifications	
Signal type	Digital Input
Functional safety related parameters	
Safety Integrity Level (SIL)	SIL 2
Supply	
Connection	terminals 23+, 24- or power feed module/Power Rail
Rated voltage U_r	20 ... 30 V DC
Rated current I_r	approx. 100 mA
Power dissipation/power consumption	$\leq 2 \text{ W} / 2.2 \text{ W}$
Interface	
Programming interface	programming socket
Input	
Connection side	field side
Connection	Input I: 2-wire sensor: terminals 1+, 3- three wire sensor: terminals 1+, 2- and 3 input II: terminals 13+, 14- start-up override;
Input I	2- or 3-wire sensor, sensor acc. to EN 60947-5-6 (NAMUR) or mechanical contact
Open circuit voltage/short-circuit current	22 V / 40 mA
Input resistance	4.7 k Ω
Switching point/switching hysteresis	logic 1: > 2.5 mA ; logic 0: < 1.9 mA
Pulse duration	> 50 μ s
Input frequency	0.001 ... 12000 Hz
Line fault detection	breakage I $\leq 0.15 \text{ mA}$; short-circuit I > 4 mA
Input II	startup override: 1 ... 1000 s, adjustable in steps of 1 s
Active/Passive	I > 4 mA (for min. 100 ms) / I < 1.5 mA
Open circuit voltage/short-circuit current	18 V / 5 mA
Output	
Connection side	control side
Connection	output I: terminals 10, 11, 12 output II: terminals 16, 17, 18 output III: terminals 19+, 20- output IV: terminals 8+, 7-
Output I, II	signal, relay
Contact loading	250 V AC / 2 A / $\cos \phi \geq 0.7$; 40 V DC / 2 A
Mechanical life	5×10^7 switching cycles
Energized/De-energized delay	approx. 20 ms / approx. 20 ms
Output III	electronic output, passive
Contact loading	40 V DC
Signal level	1-signal: (L+) -2.5 V (50 mA, short-circuit/overload proof) 0-signal: blocked output (off-state current $\leq 10 \mu$ A)
Output IV	analog
Current range	0 ... 20 mA or 4 ... 20 mA
Open loop voltage	$\leq 24 \text{ V DC}$
Load	$\leq 650 \Omega$
Fault signal	downscale I $\leq 3.6 \text{ mA}$, upscale $\geq 21.5 \text{ mA}$ (acc. NAMUR NE43)
Collective error message	Power Rail
Transfer characteristics	
Input I	
Measurement range	0.001 ... 12000 Hz
Resolution	0.1 % of the measurement value , $\geq 0.001 \text{ Hz}$
Accuracy	0.1 % of the measurement value , > 0.001 Hz
Measuring time	< 100 ms
Influence of ambient temperature	0.003 %/K (30 ppm)
Output I, II	
Response delay	$\leq 200 \text{ ms}$
Output IV	
Resolution	< 10 μ A
Accuracy	< 20 μ A
Influence of ambient temperature	0.005 %/K (50 ppm)
Galvanic isolation	
Input I/other circuits	reinforced insulation according to IEC/EN 61010-1, rated insulation voltage 300 V _{eff}
Output I, II/other circuits	reinforced insulation according to IEC/EN 61010-1, rated insulation voltage 300 V _{eff}
Mutual output I, II, III	reinforced insulation according to IEC/EN 61010-1, rated insulation voltage 300 V _{eff}
Output III/power supply and collective error	basic insulation according to IEC/EN 61010-1, rated insulation voltage 50 V _{eff}

Release date 2018-05-08 Date of issue 2018-05-08 231193_eng.xml

Refer to "General Notes Relating to Pepperl+Fuchs Product Information".

Pepperl+Fuchs Group
www.pepperl-fuchs.com

USA: +1 330 486 0002
pa-info@us.pepperl-fuchs.com

Germany: +49 621 776 2222
pa-info@de.pepperl-fuchs.com

Singapore: +65 6779 9091
pa-info@sg.pepperl-fuchs.com

Output III/IV	basic insulation according to IEC/EN 61010-1, rated insulation voltage 50 V _{eff}
Output IV/power supply and collective error	functional insulation acc. to IEC 62103, rated insulation voltage 50 V _{eff}
Start-up override/power supply and collective error	functional insulation acc. to IEC 62103, rated insulation voltage 50 V _{eff}
Interface/power supply and collective error	functional insulation acc. to IEC 62103, rated insulation voltage 50 V _{eff}
Interface/output III	basic insulation according to IEC/EN 61010-1, rated insulation voltage 50 V _{eff}
Indicators/settings	
Display elements	LEDs , display
Control elements	Control panel
Configuration	via operating buttons via PACTware
Labeling	space for labeling at the front
Directive conformity	
Electromagnetic compatibility	
Directive 2014/30/EU	EN 61326-1:2013 (industrial locations)
Low voltage	
Directive 2014/35/EU	EN 61010-1:2010
Conformity	
Electromagnetic compatibility	NE 21:2006
Degree of protection	IEC 60529:2001
Ambient conditions	
Ambient temperature	-20 ... 60 °C (-4 ... 140 °F)
Mechanical specifications	
Degree of protection	IP20
Connection	screw terminals
Mass	300 g
Dimensions	40 x 119 x 115 mm (1.6 x 4.7 x 4.5 inch) , housing type C3
Mounting	on 35 mm DIN mounting rail acc. to EN 60715:2001
Data for application in connection with hazardous areas	
Certificate	PF 08 CERT 1216 X
Marking	⊕ II 3G Ex nA nC IIC T4 Gc
Output I, II	
Contact loading	50 V AC/2 A/cos φ > 0.7; 40 V DC/1 A resistive load
Ambient conditions	
Ambient temperature	-20 ... 50 °C (-4 ... 122 °F)
Directive conformity	
Directive 2014/34/EU	EN 60079-0:2012+A11:2013 , EN 60079-15:2010
International approvals	
UL approval	E223772
General information	
Supplementary information	Observe the certificates, declarations of conformity, instruction manuals, and manuals where applicable. For information see www.pepperl-fuchs.com .

Release date 2018-05-08 08:06 Date of issue 2018-05-08 231193_eng.xml

Maximum Switching Power of Output Contacts

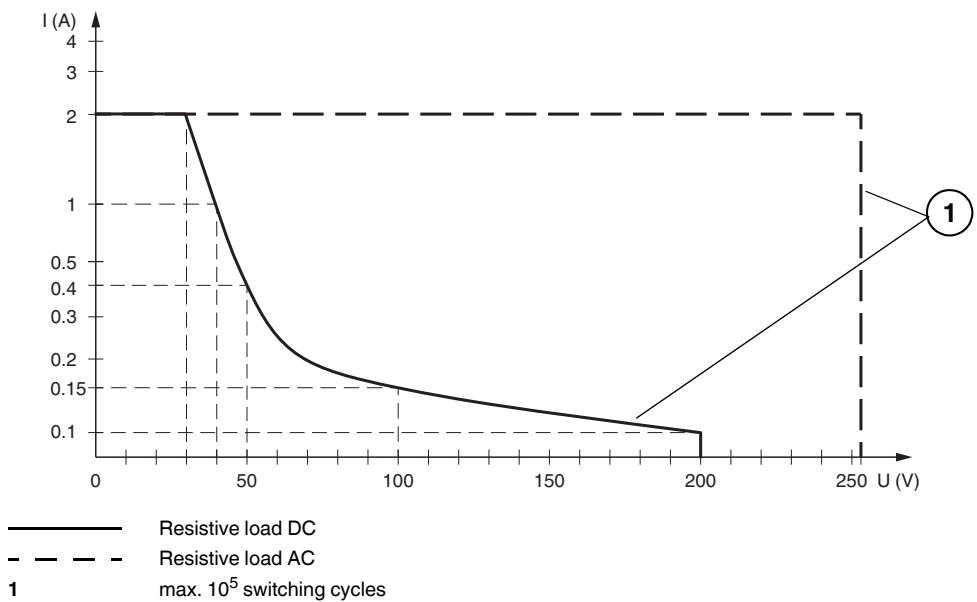

Accessories

Power feed module KFD2-EB2

The power feed module is used to supply the devices with 24 V DC via the Power Rail. The fuse-protected power feed module can supply up to 150 individual devices depending on the power consumption of the devices. A galvanically isolated mechanical contact uses the Power Rail to transmit collective error messages.

Power Rail UPR-03

The Power Rail UPR-03 is a complete unit consisting of the electrical inset and an aluminium profile rail 35 mm x 15 mm. To make electrical contact, the devices are simply engaged.

Profile Rail K-DUCT with Power Rail

The profile rail K-DUCT is an aluminum profile rail with Power Rail insert and two integral cable ducts for system and field cables. Due to this assembly no additional cable guides are necessary.



Power Rail and Profile Rail must not be fed via the device terminals of the individual devices!

PACTware™

Device-specific drivers (DTM)

Adapter K-ADP-USB

Programming adapter for parameterisation via the serial USB interface of a PC/Notebook

Release date 2018-05-08 08:06 Date of issue 2018-05-08 231193_eng.xml

Refer to "General Notes Relating to Pepperl+Fuchs Product Information".