

Main

Range of product	Twido
Product or component type	Compact base controller
Concept	Transparent Ready
Discrete I/O number	40
Discrete input number	24
Discrete input voltage	24 V
Discrete input voltage type	DC
Discrete output number	14 for relay 2 for transistor
[Us] rated supply voltage	100...240 V AC
Number of I/O expansion module	7
Use of slot	Memory cartridge
Data backed up	Internal RAM (external battery TSXPLP01) 3 years
Integrated connection type	Non isolated serial link mini DIN, Modbus/character mode master/slave RTU/ASCII (RS485) half duplex, 38.4 kbit/s Ethernet TCP/IP RJ45, , 10/100 Mbit/s, 1 twisted pair transparent ready class A10 Power supply Serial link interface adaptor (RS232C/RS485)
Complementary function	Event processing PID

Complementary

Discrete input logic	Sink or source
Input voltage limits	20.4...26.4 V
Discrete input current	11 mA for I0.0 to I0.1 11 mA for I0.6 to I0.7 7 mA for I0.2 to I0.5 7 mA for I0.8 to I0.23
Input impedance	2100 Ohm for I0.0 to I0.1 2100 Ohm for I0.6 to I0.7 3400 Ohm for I0.2 to I0.5 3400 Ohm for I0.8 to I0.23
Filter time	150 µs + programmed filter time for I0.6 to I0.23 at state 0 35 µs + programmed filter time for I0.0 to I0.5 at state 1 40 µs + programmed filter time for I0.0 to I0.5 at state 0 40 µs + programmed filter time for I0.6 to I0.23 at state 1

Disclaimer: This documentation is not intended as a substitute for and is not to be used for determining suitability or reliability of these products for specific user applications

Insulation between channel and internal logic	1500 Vrms for 1 minute
Insulation resistance between channel	None
Minimum load	0.1 mA
Contact resistance	<= 30000 µOhm
Load current	2 A at 240 V AC inductive load, operating rate = 30 cyc/mn for relay output 2 A at 240 V AC resistive load, operating rate = 30 cyc/mn for relay output 2 A at 30 V DC inductive load, operating rate = 30 cyc/mn for relay output 2 A at 30 V DC resistive load, operating rate = 30 cyc/mn for relay output
Mechanical durability	>= 20000000 cycles for relay output
Electrical durability	>= 100000 cycles for relay output
Current consumption	128 mA at 24 V DC at state 1 128 mA at 24 V DC state 1 + input ON 170 mA at 5 V DC at state 0 240 mA at 5 V DC state 1 + input ON 5 mA at 24 V DC at state 0 90 mA at 5 V DC at state 1
I/O connection	Non-removable screw terminal block
Input/Output number	<= 152 with removable screw terminal block with I/O expansion module <= 208 with spring terminal block with I/O expansion module <= 264 with HE-10 connector with I/O expansion module
Network frequency	50/60 Hz
Supply voltage limits	85...264 V
Network frequency limits	47...63 Hz
Power supply output current	0.4 A for 24 V DC sensors
Input current	790 mA
Inrush current	<= 35 A
Protection type	Power protection with internal fuse
Power consumption in VA	65 VA at 100 V 77 VA at 264 V
Insulation resistance	> 10 MOhm at 500 V, between I/O and earth terminals > 10 MOhm at 500 V, between supply and earth terminals
Program memory	3000 instructions
Exact time for 1 Kinstruction	1 ms
System overhead	0.5 ms
Memory description	Internal RAM, 128 counters, no floating, no trigonometrical Internal RAM, 128 timers, no floating, no trigonometrical Internal RAM, 256 internal bits, no floating, no trigonometrical Internal RAM, 3000 internal words, no floating, no trigonometrical Internal RAM, double words, no floating, no trigonometrical Internal RAM, floating, trigonometrical
Free slots	1
Realtime clock	With, drift: <= 30 s/month, operating time: 30 days
Port Ethernet	10BASE-T/100BASE-TX
Communication service	BOOTP client Ethernet TCP/IP Modbus messaging Ethernet TCP/IP
Positioning functions	PWM/PLS 2 channel(s) at 7 kHz
Counting input number	2 channel(s) at 20000 Hz 32 bits 4 channel(s) at 5000 Hz 16 bits
Analogue adjustment points	1 point adjustable from 0...1023 1 point adjustable from 0 to 511 points
Status LED	1 LED for 10 or 100 Mbit/s rate (LACT) 1 LED for Ethernet status (LAN ST) 1 LED for user pilot light (STAT) 1 LED green for PWR 1 LED green for RUN 1 LED per channel green for I/O status 1 LED red for module error (ERR)
Depth	70 mm
Height	95 mm
Width	90 mm

Product weight	0.525 kg
----------------	----------

Environment

Immunity to microbreaks	10 ms
Dielectric strength	1500 V for 1 minute, between I/O and earth terminals 1500 V for 1 minute, between supply and earth terminals
Product certifications	CSA UL
Marking	CE
Ambient air temperature for operation	0...55 °C
Ambient air temperature for storage	-25...70 °C
Relative humidity	30...95 % without condensation
IP degree of protection	IP20
Operating altitude	0...2000 m
Storage altitude	0...3000 m
Vibration resistance	0.075 mm, 10...57 Hz mounting on: 35 mm symmetrical DIN rail 1 gn, 57...150 Hz mounting on: 35 mm symmetrical DIN rail 1.6 mm, 2...25 Hz mounting on: plate or panel with fixing kit 4 gn, 25...100 Hz mounting on: plate or panel with fixing kit
Shock resistance	15 gn for 11 ms

Contractual warranty

Warranty period	18 months
-----------------	-----------

Dimensions

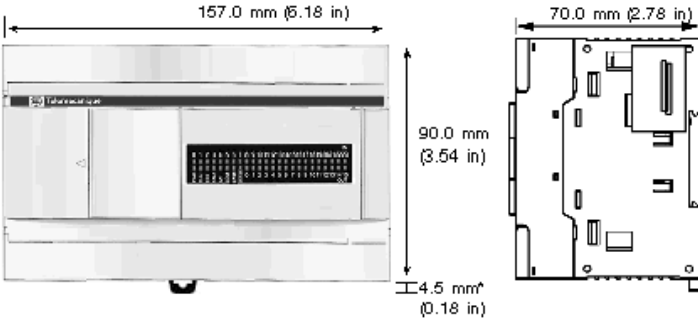

* 8.5 mm (0.33 in) when the clamp is pulled out.

Minimum Clearances for a Compact Base and Expansion I/O Modules

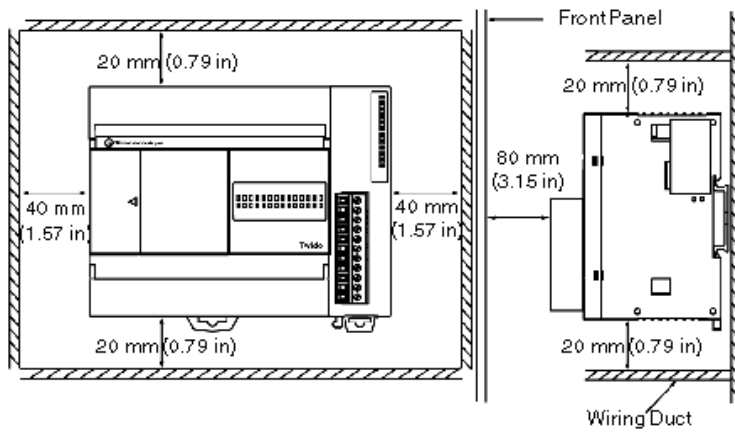

Mounting Hole Layout

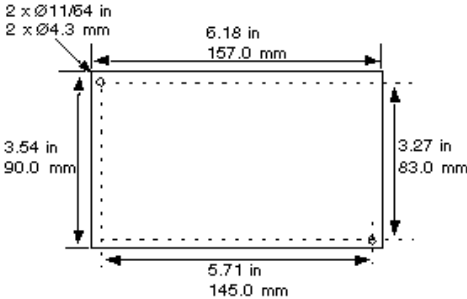

AC Power Supply Wiring Diagram

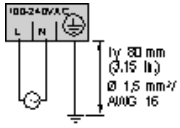

DC Source Inputs Wiring Diagrams

External Power

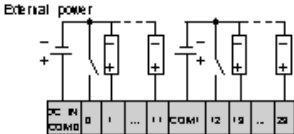

Internal Power

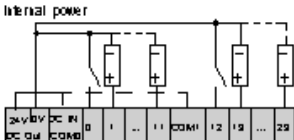

Max current: 400mA.

DC Sink Inputs Wiring Diagrams

External Power

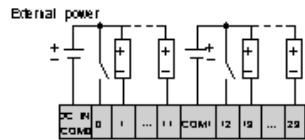

Internal Power

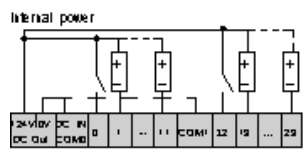

Max current: 400mA.

Relay and Transistor Outputs Wiring Diagram

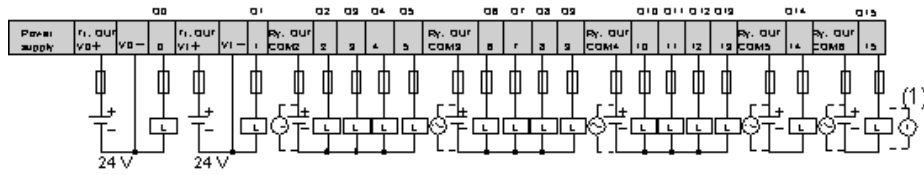

Performance Curves

I/O Usage Limits

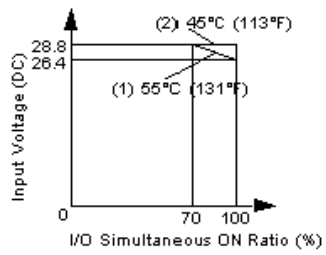

- (1) Limit for TWDLCAE40DRF, TWDLCAE40DRF, TWDLCAE40DRF and TWDLCAE40DRF
- (2) All compact bases